



Puller guide – how to choose the right tool





Dear Sir/Madam,

our sector offers with its products an ever-increasing number of tools for carrying out repairs and working in the various sectors of industry, trade and automotive operations.

It is the aim of any trader to guarantee that their customers receive high quality and quick advice at any time. The challenge is to deepen the specialist knowledge needed for sales.

We are happy to help you with this with the new puller basics for the KUKKO brand!

If your customers need a puller, you will usually be faced with the following questions:

- **What principles actually exist for the puller?**
- **Which puller is right for my problem?**
- **How does it work and what do I have to watch out for during use?**
- **Which jaws and spindles are available as an alternative for my KUKKO puller?**

In future, you will be able to answer these questions quickly and easily with the new puller basics. Kukki will reliably guide you through the 4 principles of the puller and provide you with information using product videos, photos, videos and tables.

Thank you for your interest in KUKKO products and enjoy reading and discovering.

Your KUKKO Team!

[youtube.com/kukkotools](https://www.youtube.com/kukkotools)



Usage video for external pulling



Usage video for the internal pulling



Usage video for the separating



Usage video for the ball bearing removal and installation



KUKKO on Facebook
www.facebook.com/kukkotools



The 4 puller principles at a glance
General overview of the KUKKO line
KUKKO-Technologies
Precautionary Notes and Helpful Hints

page 6 - 7
page 28- 31
page 4
page 5

General

OUTSIDE-pulling
Selection of the right external puller
Special features of series 20 and 30
Puller Jaw Basics
Spindle Basics

page 8 -19
page 8 - 9
page 10- 11
page 12 -15
page 16 -19

EXTERNAL

INTERNAL-pulling
Selection of the right internal puller device
Special features of series 21 and 22
Overview: Internal pulling with counter stay
Overview: Internal pulling with slide hammer

page 20 -23
page 20
page 21
page 22 -23
page 22 -23

INTERNAL

SEPARATING
Selection of the right separating device
Special features of series 15, 17 and 18

page 24 -25
page 24
page 25

SEPARATING

BALL BEARING removal and installation
Selection of the right bearing puller
Overview: Ball bearing removal and installation

page 26 -27
page 26
page 27

BALL BEARING



The geometry of the cross-beam and sliding parts has been optimized to ensure particularly easy movement of the extractor jaws along the cross-beam.

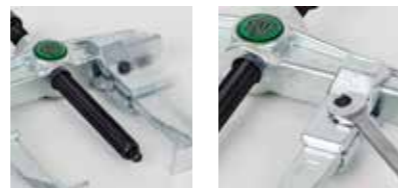

A manual adjustment knurl allows rapid loosening and adjusting of the extractor jaws on the cross-beam without using a wrench.



The cross-hooks guarantee maximum stability due to the mounting of the puller jaws in the sliding part.



The operating nut is easy to turn thanks to a built in pressure bearing. Resistance from friction is reduced to a minimum.



Smooth-running, self-adjusting spring-back jaws.



Automatic tensioning and centering of the extractor jaws.



By turning the locking bolt the jaws are centered and tensioned and therefore firmly grip the piece to be pulled off. This prevents the jaws moving or slipping off.



Tools with hydraulic function.



Unique, simple pullback of the nut splitter chisel to remove it from deformed or split nuts. The chisel does not get stuck in the nut.



Precautionary Notes and Helpful Hints

All tools must always be used for the intended purposes under the envisioned conditions and within their postulated limitations.

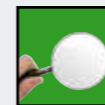

Check the condition of your tools at regular intervals, and replace any damaged or worn parts.

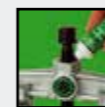

Keep the threads of all pressure spindle and cross-beam clean and well oiled. (KUKKO special sliding grease for pressure spindle Art. 699999)



Before you start work, acquaint yourself with the proper use of the tool or tools in question, with due attention to pertinent safety measures.



If anything at all is unclear about any of the above, it is best to call the factory for some firsthand advice.



Prior to starting work, make sure that the pulling tool is in good working order.

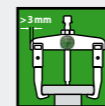

Double-check the tool for correct mounting, and monitor the forces incidental to the pulling process.

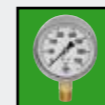

Never violate the maximum load data prescribed for the tool in question. Use a torque wrench (for mechanical/pressure-screw-driven tools) or a pressure gauge (hydraulic/pump-driven tools) to keep tabs on the applied forces.



Always wear suitable personal protective equipment, including protective goggles.

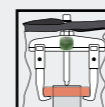

Always wrap the pulling tool and the workpiece in a protective blanket as a precaution against the potential effects of sudden release.



If the tool appears to be overloaded, works sluggishly, or is otherwise negatively conspicuous, interrupt the pulling process, and replace the tool with a larger model.



Never use an electric- or pneumatic-powered impact/hammer drill for driving a pulling tool.



Never use extensions to increase the applied torque.

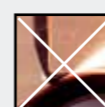

Never alter a pulling tool or related product in any way.

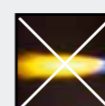

Since heat detracts from the thermal properties of steel, and since some parts require heating to facilitate their removal, remember to never heat the pulling tool along with the part.

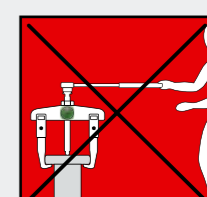
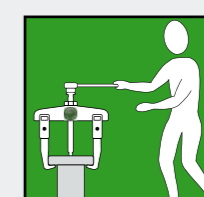
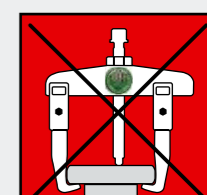
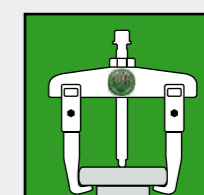
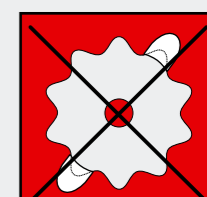
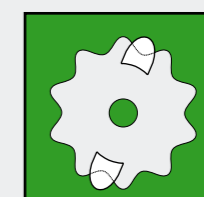
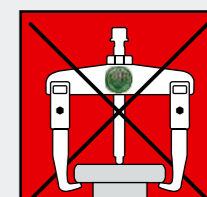
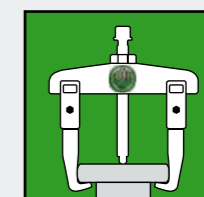
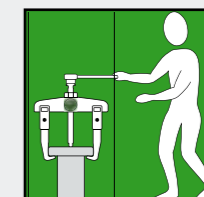
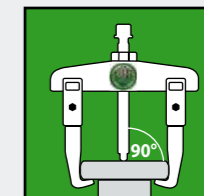
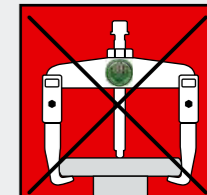
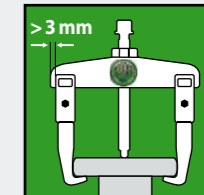

EXTERNAL



The part to be removed is on a shaft and is freely accessible from the outside!

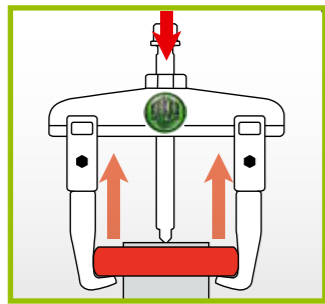
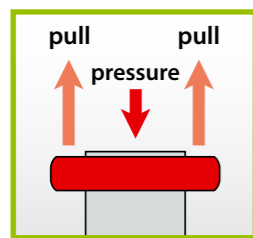

Use an **EXTERNAL** puller
see pages:
8 - 19

INTERNAL



The part to be removed is in a recess!

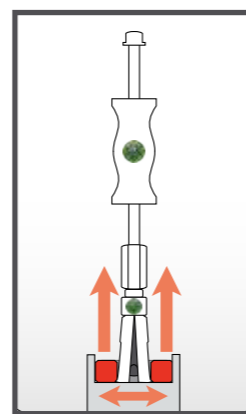
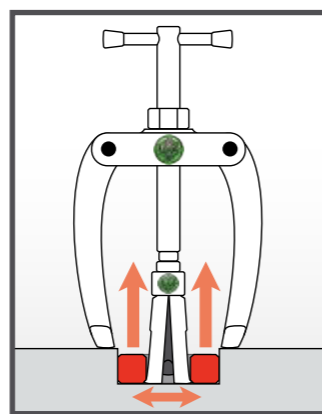
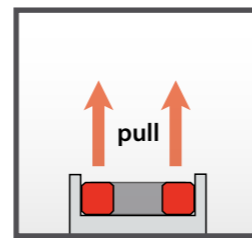
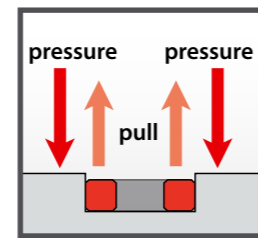

Use an **INTERNAL** puller
see pages:
20 - 23

SEPARATING



The part to be removed is level. It is not possible to use standard puller jaws!

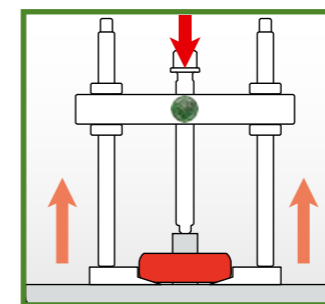
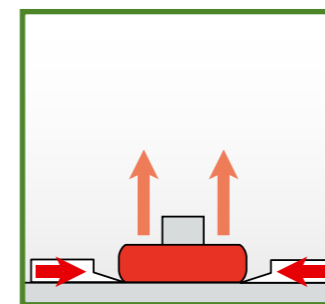
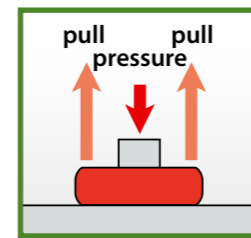

Use an **SEPARATING** device
see pages:
24 - 25

BALL BEARING



The ball bearing is in a housing and on a shaft at the same time.

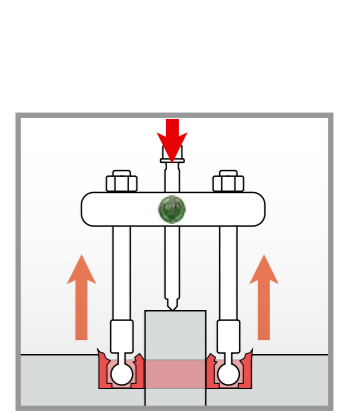
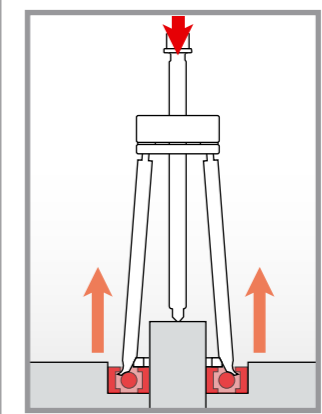
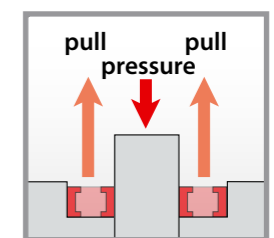

Use an **BALL BEARING** extractor
see pages:
26 - 27

Selection of the right outside puller



1st step: Measuring the space available

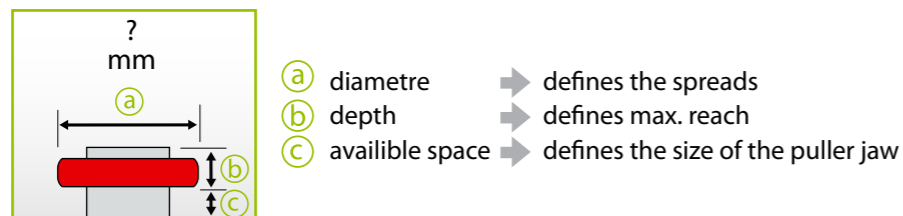

2nd step: Selection of the puller type

Requirement:

- The puller is used for various applications.
- The puller must be able to change characteristics e.g. increase the reach etc.

Recommendation of KUKKO

Puller with sliding, parallel puller jaws

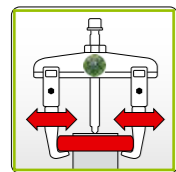

The puller jaws can be moved continuously (even asymmetrically) on the cross-beam, and can be fixed to the cross-beam using a bolt connection or knurled knob.

Series available

11 ; 20; 20+; 20-S; 20+S; 20-S-T; 20-S+T; 30; 30+; 30-S; 30+S; 30-S-T; 30-S+T; 110; 120; 130

Requirement:

- The same removal application is always used.

Recommendation of KUKKO

Puller with self-centering puller jaws (autogrip)

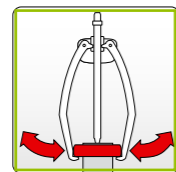

The two puller jaws are connected to each other. The pullers therefore ensure automatic self-tensioning and self-centering of the jaws.

Series available

43; 44; 45; 482; 483; 844; 845

Requirement:

- The same removal application is always used.
- Same application at different depths.

Recommendation of KUKKO

Puller with swivel puller jaws

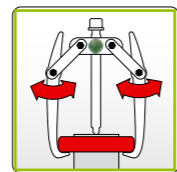

The jaws and the cross-beam are connected by movable brackets. As the spindle pulls, the jaws tense and tighten firmly. An additional option is swivel-jaws pullers. Reversing the puller jaws expands or reduces the reach.

Series available

41; 42; 46; 47; 201; 203; 205; 206; 207; 208; 209

Requirement:

- The bearing is flush.
- It is especially important that the puller arms do not slip off.

Recommendation of KUKKO

Puller with side tension clamps.

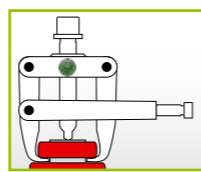

To remove flush parts the puller jaws grab beneath the part to be removed when pulling on the side clamps and loosen the part even before the actual pulling process. The clamp presses the puller jaws securely onto the part to be removed. This ensures that the puller jaws do not slip off.

Series available

204; 210

3rd step: How much force is required?

A normal amount of pressure is required.

High pressure is required because the part to be removed is particularly secure, or rusted.

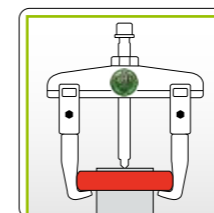

Puller with mechanical pressure spindle

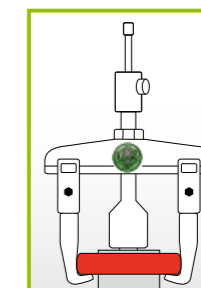

Puller with long hydraulic spindle

4th step: Select model

The selected pulling tool normally states the necessary power and pulling force. However, in order to be absolutely sure, you should always choose the largest possible model for dimension ranges which cross over.

Detailed dimension and performance details for all models can be found at www.KUKKO.com

For example:

1st step: Measuring the space available

diameter: 142 mm / 120 mm / 135 mm
 depth: 135 mm / 120 mm / 220 mm
 available space: unlimited

2nd step: Selection of the puller type

Specification: There must be pulled various bearings at different depths.
 Target: We are looking for a puller which can be individually adapted.
According to the puller guide should be used pullers with sliding puller arms that are always parallel.

3rd step: How much force is needed?

The bearings are smooth-running on the shaft.
According to the puller guide should be used a puller with a mechanical spindle.

4th step: Select model

According to the KUKKO website choose the pullers from series 20 and 30 in size 2.

The decision falls to : 30-2+ and 2-V-150-S

Advantage:

- with the 3-jaw model, you have the best possible load distribution and a particularly secure hold.
- You can adjust your puller to the relevant reach by buying the extensions.
- The quick adjusting capability allows the reach to be changed quickly.

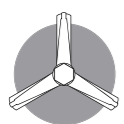

You should always give a 3-arm puller preference if the access conditions permit. The uniform load distribution guarantees a particularly secure hold on the to be extracted part.

Mode of operation

STANDARD

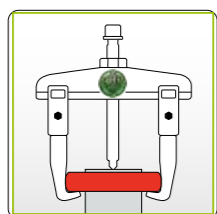

external pulling is the most common type of pulling. The part to be extracted such as a gear wheel, pulley or ball bearing, is gripped from the outside. The part is loosened from the shaft by the pull of the pressure screw.

as INTERNAL extractor

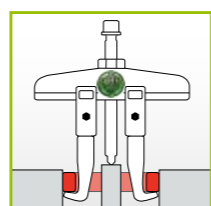

The external pullers can also be used as internal extractors by turning the jaws. *Important: When used as internal extractors, a fixed center point is required to brace the pressure screw of the products in these series.*

Accessories: Modular extensions

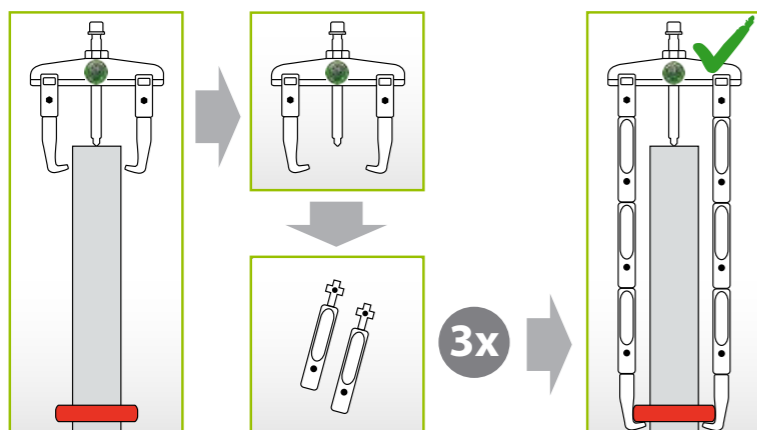

For the 20 and 30 series, we offer modular extensions. If the part to be removed sits deep inside a shaft, jaw extensions will be needed.

Accessories: Side clamp

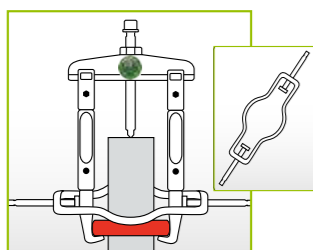

The side clamp is available separately (No. 219-1). It is attached to the puller jaw after the puller has been fitted and prevents slippage of the puller jaw under very high forces.

Accessories: Grease hydraulic pressure spindle

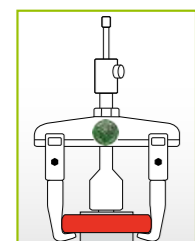

The hydraulic spindle ensures controlled and secure operating of 7-20 t. It uses the entire capability of the puller, over and above what can be achieved with a mechanical spindle. When replacing a mechanical spindle with a hydraulic one, there is also a considerable reduction in the drive force which needs to be used. **See also pages: 16, 18, 19**

Accessories: auxiliary grease hydraulic rams

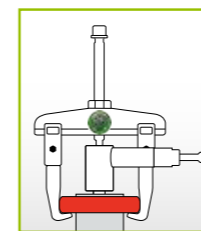

For use with mechanical KUKKO pullers from size 3.

The auxiliary grease hydraulic rams are a good tool for significantly increasing the pressure when removing very secure parts. The hydraulic rams are simply secured between the spindle and shaft with the mechanical spindle.

No conversion of the puller is needed!

See also page: 16

Accessories: Puller jaws

Pullers in series 20 and 30 can easily be adjusted using different puller jaws lengths and types.

Which puller jaws are right for which puller?

The puller jaws that start with **1-** → fit all pullers of size **-1** and **-10**

The puller jaws that start with **2-** → fit all pullers of size **-2** and **-20**

The puller jaws that start with **3-** → fit all pullers of size **-3** and **-30**

The puller jaws that start with **3-** → can also use by the pullers of size **-4** and **-40**

Example:

20-2 → has the puller jaws 2-150-P

→ can also use : 2-151-P; 2-152-P; 2-153-P; 2-154-P; 2-155-P

→ can also use long puller jaws such as: 2-300-P; 2-301-P; 2-302-P; 2-303-P



Safety instructions

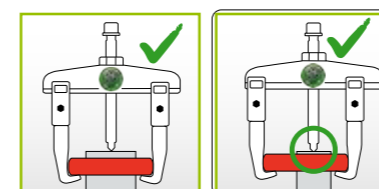

The puller must be centrally positioned for center shafts. If the shaft is not centered, pulling with parallel jaws may result asymmetrical pulling.

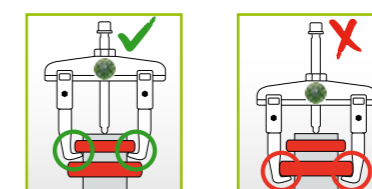

If there are several parts to be pulled, always remove them one-by-one. Never remove several parts simultaneously.

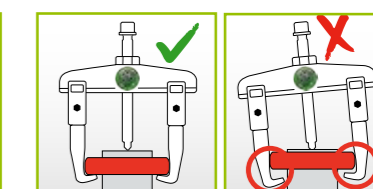

Jaws must always be positioned directly below the part to be removed.

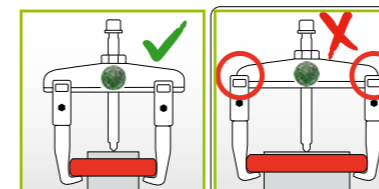

The jaws of the leg must be set firmly and completely against the cross-beam



If there is adequate free space around the part, we recommend a 3-jaw puller for optimal force distribution.

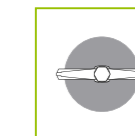

A 2-jaw puller is always used in situations where there is insufficient space for a 3-jaw puller.

Pulling jaws for 2-jaw pullers, series 20

Dimensions of the puller jaws	A	B	C	D	E	mm			Quick adjust TECHNOLOGY	Art.- No.	suitable for KUKKO-pullers:	mm	
	mm	mm	mm	mm	mm								mm
	3,0	20	15	31	10	100				1-90-P	1-92-P	20-1; 20-10	90-120
	4,0	24	18	40	9	150				2-150-P	2-152-P	20-2; 20-20	160-200
	4,0	35	37	67	20	200				3-200-P	3-202-P	20-3; 20-30; 20-4; 20-40	250-650
	3,0	20	15	31	10	200				1-190-P	1-192-P	20-1; 20-10	90-120
	4,0	24	18	40	9	250				1-250-P	1-252-P	20-1; 20-10	90-120
	4,0	35	37	67	20	300				2-300-P	2-302-P	20-2; 20-20	160-200
	4,0	35	37	67	20	300				3-300-P	3-302-P	20-3; 20-30; 20-4; 20-40	250-650
	4,0	35	37	67	20	400				3-400-P	3-402-P	20-3; 20-30; 20-4; 20-40	250-650
	4,0	35	37	67	20	500				3-500-P	3-502-P	20-3; 20-30; 20-4; 20-40	250-650
	2,6	30	7	14	-	100				1-91-P	1-93-P	20-1; 20-10	90-120
	4,0	32	8	19	-	150				2-151-P	2-153-P	20-2; 20-20	160-200
	6,5	35	17	52	-	200				3-201-P	3-203-P	20-3; 20-30	250-350
	2,6	30	7	14	-	200				1-191-P	1-193-P	20-1; 20-10	90-120
	2,6	30	7	14	-	250				1-251-P	1-253-P	20-1; 20-10	90-120
	4,0	32	8	30	-	300				2-301-P	2-303-P	20-2; 20-20	160-200
	6,5	35	17	40	-	300				3-301-P	3-303-P	20-3; 20-30	250-350
	6,5	35	17	40	-	400				3-401-P	3-403-P	20-3; 20-30	250-350
	6,5	35	17	40	-	500				3-501-P	3-503-P	20-3; 20-30	250-350
	3,0	24	7	12	15	100				1-94-P	1-95-P	20-1; 20-10	90-120
	3,0	24	7	12	15	200				1-194-P	1-195-P	20-1; 20-10	90-120
	3,0	24	7	12	15	250				1-254-P	1-255-P	20-1; 20-10	90-120

EXTERNAL

EXTERNAL



Pulling jaws for 3-jaw pullers, series 30

Dimensions of the puller jaws	A	B	C	D	E	J mm	Image	Art.-No.	Quick adjust TECHNOLOGY	Art.-No.	suitable for KUKKO-pullers:	Image	mm
	mm	mm	mm	mm	mm								
 Dimensions: A, B, C, D, E	3,0	20	15	31	10	100		1-90-S 2-150-S 3-200-S		1-92-S 2-152-S 3-202-S	30-1; 30-10 30-2; 30-20 30-3; 30-30; 30-4; 30-40		90-120 160-200 250-650
	4,0	24	18	40	9	150							
	4,0	35	37	67	20	200							
 Dimensions: A, B, C, D, E	3,0	20	15	31	10	200		1-190-S 1-250-S 2-300-S 3-300-S 3-400-S 3-500-S		1-192-S 1-252-S 2-302-S 3-302-S 3-402-S 3-502-S	30-1; 30-10 30-1; 30-10 30-2; 30-20 30-3; 30-30; 30-4; 30-40 30-3; 30-30; 30-4; 30-40 30-3; 30-30; 30-4; 30-40		90-120 90-120 160-200 250-650 250-650 250-650
	4,0	24	18	40	9	250							
	4,0	35	37	67	20	300							
	4,0	35	37	67	20	300							
	4,0	35	37	67	20	400							
	4,0	35	37	67	20	500							
 Dimensions: A, B, C, D	2,6	30	7	14	-	100		1-91-S 2-151-S 3-201-S		1-93-S 2-153-S 3-203-S	30-1; 30-10 30-2; 30-20 30-3; 30-30		90-120 160-200 250-350
	4,0	32	8	19	-	150							
	6,5	35	17	52	-	200							
 Dimensions: A, B, C, D	2,6	30	7	14	-	200		1-191-S 1-251-S 2-301-S 3-301-S 3-401-S 3-501-S		1-193-S 1-253-S 2-303-S 3-303-S 3-403-S 3-503-S	30-1; 30-10 30-1; 30-10 30-2; 30-20 30-3; 30-30 30-3; 30-30 30-3; 30-30		90-120 90-120 160-200 250-350 250-350 250-350
	2,6	30	7	14	-	250							
	4,0	32	8	30	-	300							
	6,5	35	17	40	-	300							
	6,5	35	17	40	-	400							
	6,5	35	17	40	-	500							
 Dimensions: A, B, C, D, E	3,0	24	7	12	15,0	100		1-94-S		1-95-S	30-1; 30-10		90-120
 Dimensions: A, B, C, D, E	3,0	24	7	12	15,0	200		1-194-S 1-254-S		1-195-S 1-255-S	30-1; 30-10 30-1; 30-10		90-120 90-120
	3,0	24	7	12	15,0	250							

EXTERNAL

EXTERNAL



Mechanical pressure spindle

For use with KUKKO pullers of all sizes



KUKKO pressure spindles with milled thread have been specifically engineered for use in KUKKO pullers.

The pressure spindles are specially coated and therefore guarantee particularly good sliding properties in the thread.

The mounted, freely-rotating centering point protects the shaft against damage when applying the pulling force.

The spindle heads have a band which prevents the wrench from slipping during the pulling process. The spindle head and the spindle band (see diagram below) are lasered with the item number.



Long hydraulic spindle

For use with KUKKO pullers of all sizes



Due to their high pressure performance, the hydraulic spindles ensure very secure parts can be removed quickly and effortlessly.

The hydraulic spindle ensures controlled and safe working. It uses the entire capability of the puller, over and above what can be achieved with a mechanical spindle.

The application of hydraulic pulling force must always be controlled by the use of a torque wrench.



Auxiliary hydraulic ram

For use with mechanical KUKKO pullers from size 3



The hydraulic rams are a good tool for significantly increasing the pressure when pulling particularly secure parts.

The hydraulic rams are secured between the spindle and the shaft using the mechanical spindle. No conversion of the puller is required!



Puller spindle maintenance

The spindle must always be kept well lubricated. We recommend the use of KUKKO special sliding grease for pressure spindle (Art. No.: 699999), or KUKKO Bio Multi Oil (Art. No.: 699990). A tube of KUKKO special sliding grease for pressure spindle is free with every order of an original KUKKO puller.



Mechanical spindle



Art.-No.

6

14

160

Pressure screw

Ø

L

mm

mm

thread	Art.-No.	barcode	suitable for	thread	mm	mm	SW mm						
M 8	608080	-176241	48, 482-1	M 8	8	80	-	-	X	-	X	-	
	608130	-481086	482-2, 483-2	M 8	8	130	-	-	X	-	X	-	
M 9	609087	-102493	41-1, 42-1, 43-1, 43-11, 43-12, 43-2	M 9	9	87	-	-	X	-	X	-	
	609105	-101403	41-2, 42-2, 43-3, 43-13	M 9	9	105	-	-	X	-	X	-	
M 10	610070	-362446	41-0, 42-0	M 10	10	75	13	X	-	-	X	-	
	610094	-122118	204-0	M 10	10	94	-	-	X	-	-	X	
	610110	-433726	208-0, 209-0, 112-1, 112-10	M 10	10	120	8	X	-	-	-	X	
M 12x1,5	612080	-238468	201-0, 202-0, 203-0	M 12x1,5	12	85	14	X	-	X	-	-	
	612110	-112881	205-00, 206-00, 207-00	M 12x1,5	12	110	13	X	-	X	-	-	
	612130	-077081	18-0, 44-1, 45-1	M 12x1,5	12	130	13	X	-	X	-	-	
	612131	-425073	14-01, 14-1	M 12x1,5	12	130	13	X	-	-	-	X	
M 12	612150	-790201	41-3, 42-3	M 12x1,5	12	150	13	X	-	X	-	-	
	612200	-480744	482-3, 483-3	M 12	12	210	10	X	-	-	-	X	
M 14x1,5	614135	-074271	12-1, 30-1, 30-1+, 30-1-2, 30-10, 30-10+, 30-10-2, 32-1, 33, 112-2, 201-1, 202-1, 203-1, 30-1-S, 30-1+S, 30-10-S, 30-10+S, 30-10SP, 30-1-S-T, 30-10-S-T, 30-1+S-T, 30-10+S-T,	M 14x1,5	14	135	17	X	-	X	-	-	
	614160	-112966	20-1, 20-10, 20-10-V, 44-2, 45-2, 112-20, 113-20, 205-01, 206-01, 207-01, 208-01, 209-01, 20-1-S, 20-10-S, 20-1+S, 20-10+S	M 14x1,5	14	160	17	X	-	X	-	-	
	614200	-838576	41-4, 42-4	M 14x1,5	14	200	17	X	-	X	-	-	
	614241	-976940	70-2, 201-5, 202-5	M 14x1,5	14	240	17	X	-	X	-	-	
	614250	-306709		M 14x1,5	14	250	17	X	-	X	-	-	
M 16	616160	-284236	14-2	M 16	16	145	17	X	-	-	-	X	
	616202	-264351	14-3, 14-03	M 16	16	185	17	X	-	-	-	X	
	616270	-480829	482-4, 483-4	M 16	16	270	13	X	-	-	-	X	
	616325	-480904	482-5, 483-5	M 16	16	325	13	X	-	-	-	X	
M 16x1,5	616220	-420856	112-3, 113-3	M 16x1,5	16	220	17	X	-	X	-	-	
M 18x1,5	618105	-073779	17-2, 204-1	M 18x1,5	18	105	19	X	-	X	-	-	
	618175	-074356	12-2, 18-1, 32-2	M 18x1,5	18	175	19	X	-	X	-	-	
M 18x1,5	618210	-113048	44-3, 45-3	M 18x1,5	18	210	19	X	-	X	-	-	
	620162	-816040	28-1	M 20*	20	160	24	X	X	-	-	X	
M20 x 2,5 Regelgewinde	620172	-817946	28-2	M 20	20	170	24	X	X	-	-	X	
	620230	-818028	28-3	M 20*	20	230	24	X	X	-	-	X	
	620250	-818103	28-4	M 20*	20	250	24	X	X	-	-	X	
	621130	-124358	204-2, 204-02	G 1/2"	20,955	130	22	X	-	X	-	-	
G 1/2"	621220	-268373	20-20-3, 20-20+3, 30-2, 30-2+, 30-2-3, 30-20, 30-20+, 30-20-3, 31-1, 31-2, 200-U, 201-2, 202-2, 203-2, 205-02, 206-02, 207-02, 208-02, 209-02, 210-1, 210-01, 301-3, 301-4, 20-2-S, 20-2+S, 20-20-S, 20-20+S, 20-20SP, 30-2-S, 30-2+S, 30-20-S, 30-20+S, 30-20SP, 17-3, 18-2, 20-2, 20-20, 20-2+, 20-20+, 20-2-S, 20-20-S, 30-2, 30-20, 30-2+, 30-20+, 30-2-S, 30-20-S	G 1/2"	20,955	210	22	X	-	X	-	-	
	621300	-765346	41-5, 42-5	G 1/2"	20,955	300	22	X	-	X	-	-	
	621355	-236228	70-4, 112-4, 113-4	G 1/2"	20,955	355	24	X	-	X	-	-	
	623260	-113123	12-3, 44-4, 45-4	G 5/8"	22,911	260	24	X	-	X	-	-	
	623325	-125263	44-5, 45-5, 113-5, 210-2, 210-3	G 5/8"	22,911	325	24	X	-	X	-	-	
	623400	-765353	44-6, 45-6	G 5/8"	22,911	400	24	X	-	X	-	-	
	623450	-832796	45-7	G 5/8"	22,911	450	24	X	-	X	-	-	
	G 3/4"	626300	-765360	18-3, 20-3, 20-3+, 20-3-3, 20-3-4, 20-3-5, 20-30, 20-30+, 20-30-3, 20-30-4, 20-30-5, 30-3, 30-3+, 30-3-3, 30-3-4, 30-3-5, 201-3, 201-4, 202-3, 202-4, 203-3, 203-4, 205-1, 206-1, 207-1, 20-3-S, 20-3+S, 20-30-S, 20-30+S, 20-30SP, 30-3-S, 30-3+S, 30-3SP	G 3/4"	26,441	300	27	X	-	X	-	-
		626400	-125423	12-4, 205-2, 205-3, 206-2, 206-3, 207-2, 207-3	G 3/4"	26,441	400	27	X	-	X	-	-
		626500	-765377		G 3/4"	26,441	500	27	X	-	X	-	-
G 1"	633400	-765384	18-4, 11-0, 20-4, 46-1, 47-1	G 1"	33,249	400	36	X	-	X	-	-	
	633500	-893452	20-AV, 46-2-A, 47-2-A	G 1"	33,249	500	36	X	-	X	-	-	
	633600	-866388	12-6, 12-7	G 1"	33,249	600	36	X	-	X	-	-	
G 1 1/8"	637350	-893469	11-1, 11-2, 30-4, 30-40, 30-5	G 1 1/8"	37,897	350	41	X	-	X	-	-	
	637500	-893469	15-E	G 1 1/8"	37,897	500	41	X	-	X	-	-	
	637600	-169236	18-5, 20-5, 205-4, 207-4	G 1 1/8"	37,897	600	41	X	-	X	-	-	

Backfitting 2- and 3-jaw pullers from mechanic up to hydraulic spindle



When using pullers with hydraulic spindles, the application of hydraulic pulling force must always be controlled, i.e., by the use of a torque wrench.

Art. No.	+	max.		max. Nm
		t	kN	
20-2+	8-01	7,0	70	12
20-20	8-01	7,0	70	12
20-20+	8-01	7,0	70	12
20-2-3	8-01	7,0	70	12
20-20-3	8-01	7,0	70	12
20-3	8-02	8,5	85	14
20-3+	8-02	8,5	85	14
20-30	8-02	8,5	85	14
20-30+	8-02	8,5	85	14
20-3-3	8-02	8,5	85	14
20-3-4	8-02	8,5	85	14
20-3-5	8-02	8,5	85	14
20-30-3	8-02	8,5	85	14
20-30-4	8-02	8,5	85	14
20-30-5	8-02	8,5	85	14
20-4	8-1-B	15,0	150	45
20-4-3	8-1-B	15,0	150	45
20-4-5	8-1-F	15,0	150	45
20-40	8-1-B	15,0	150	45
20-40-4	8-1-B	15,0	150	45
20-40-5	8-1-F	15,0	150	45
20-5	8-2-M	20,0	200	30
30-2	8-01	7,0	70	12
30-2+	8-01	7,0	70	12
30-20	8-01	7,0	70	12
30-20+	8-01	7,0	70	12
30-2-3	8-01	7,0	70	12
30-20-3	8-01	7,0	70	12
30-3	8-02	10,0	100	15
30-3+	8-02	10,0	100	15
30-3-3	8-02	10,0	100	15
30-3-4	8-02	10,0	100	15
30-3-5	8-02	10,0	100	15
30-3-5	8-02	10,0	100	15

2- and 3-jaw puller with hydraulic spindle



20-2	8-01	7,0 to / 70 kN	12 Nm
20-2+	8-01	7,0 to / 70 kN	12 Nm
20-20	8-01	7,0 to / 70 kN	12 Nm
20-20+	8-01	7,0 to / 70 kN	12 Nm
20-2-3	8-01	7,0 to / 70 kN	12 Nm
20-20-3	8-01	7,0 to / 70 kN	12 Nm
20-3	8-02	8,5 to / 85 kN	14 Nm
20-3+	8-02	8,5 to / 85 kN	14 Nm
20-30	8-02	8,5 to / 85 kN	14 Nm

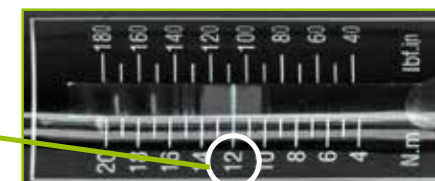

When using pullers with hydraulic spindles, the application of hydraulic pulling force must always be controlled, i.e., by the use of a torque wrench.

Art. No.	incl.	max.		max. Nm
		t	kN	
20-2-B	8-01	7	70	12
20-20-B	8-01	7	70	12
20-3-B	8-02	10	100	15
20-30-B	8-02	10	100	15
20-4-B	8-1-B	15	150	45
20-40-B	8-1-B	15	150	45
20-2-3-B	8-01	7	70	12
20-20-3-B	8-01	7	70	12
20-3-3-B	8-02	10	100	15
20-3-4-B	8-02	10	100	15
20-3-5-B	8-02	10	100	15
20-30-3-B	8-02	10	100	15
20-30-4-B	8-02	10	100	15
20-30-5-B	8-02	10	100	15
20-4-3-B	8-1-B	15	150	45
20-4-4-B	8-1-B	15	150	45
20-4-5-B	8-1-B	15	150	45
20-40-4-B	8-1-B	15	150	45
20-40-5-B	8-1-B	15	150	45
20-2+B	8-01	7	70	12
20-20+B	8-01	7	70	12
20-3+B	8-02	10	100	15
20-30+B	8-02	10	100	15
30-2-B	8-01	7	70	12
30-20-B	8-01	7	70	12
30-3-B	8-02	10	100	15
30-2-3-B	8-01	7	70	12
30-20-3-B	8-01	7	70	12
30-3-3-B	8-02	10	100	15
30-3-4-B	8-02	10	100	15
30-3-5-B	8-02	10	100	15
30-2+B	8-01	7	70	12
30-20+B	8-01	7	70	12
30-3+B	8-02	10	100	15

Selection of the right internal puller type

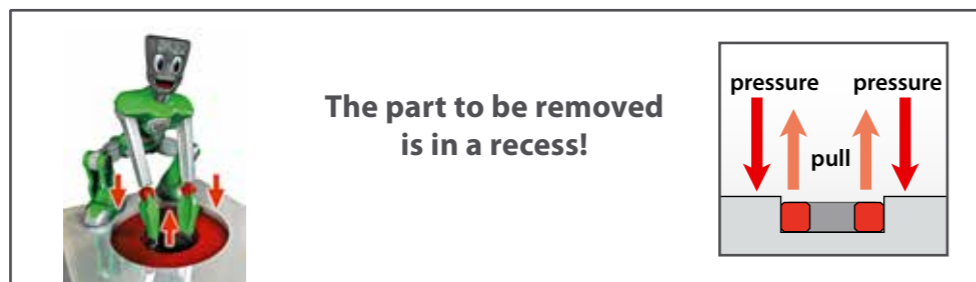

1st step: What is the interior diameter of the ball bearing

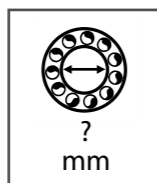

2nd step: Selection of the internal puller

<p>2 a 2- and 3-shell Internal extractors</p> <p>5-200 mm</p>	<p>2 b Segmented internal extractors for small spaces</p> <p>5-78 mm</p>	<p>2 c Needle bearing extractors</p> <p>9,6-25 mm</p>
--	---	--

3rd step: What is access like?

<p>3 a Supporting surface present → Counter stay</p>	<p>3 b NO supporting surface present → slide hammer</p>
---	--

Combinations of internal pullers with counter stays and slide hammers

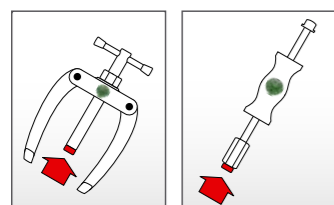

Counter stays and slide hammers can be combined with internal extractors of various sizes. The appropriate thread adapters are delivered with orders for counter stays and slide hammers. See also pages: 22-23

Mode of operation

For pulling internal ball bearings, ball bearing outer rings and bushings. The bearings are securely grasped by the internal puller, in the inner ring, and quickly removed using the clamping effect. In order to be able to remove a bearing with an internal puller, a counter support or a slide hammer from series 22 will always be required.

Accessories: Extensions

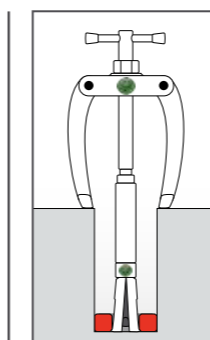

Many of the KUKKO internal extractors in the 21 series (not 21-E) can be expanded using an extension (series 21-V) for extracting parts set deep inside a bushing.

Accessories: Thread adapters

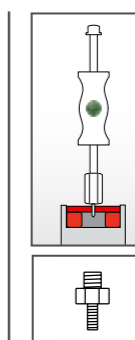

The KUKKO slide hammers can be used in combination with the thread adapters 22-1-AS anywhere where the threaded pin can be screwed directly into the part that needs to be removed.

Safety instructions for internal pulling

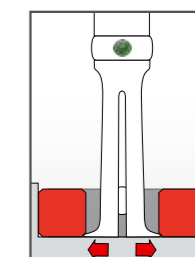
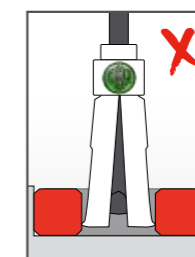
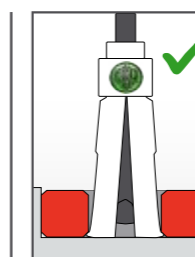
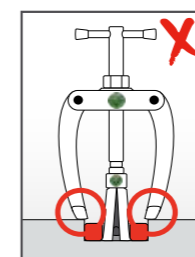
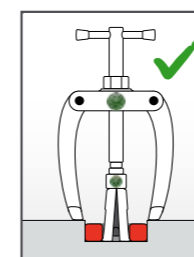

When using a counter stay, ensure that the jaws of the counter stay do not block the part being removed.

Note: the internal extractors must grip firmly underneath the part to be removed.

If there is too little space in the bushing below the part to be removed, an internal extractor from series 21-E may be used.

The QR codes guide you to more information and usage videos online

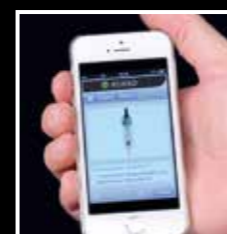

Just scan and experience KUKKO!

Combination of counter stay with internal extractors, series 21

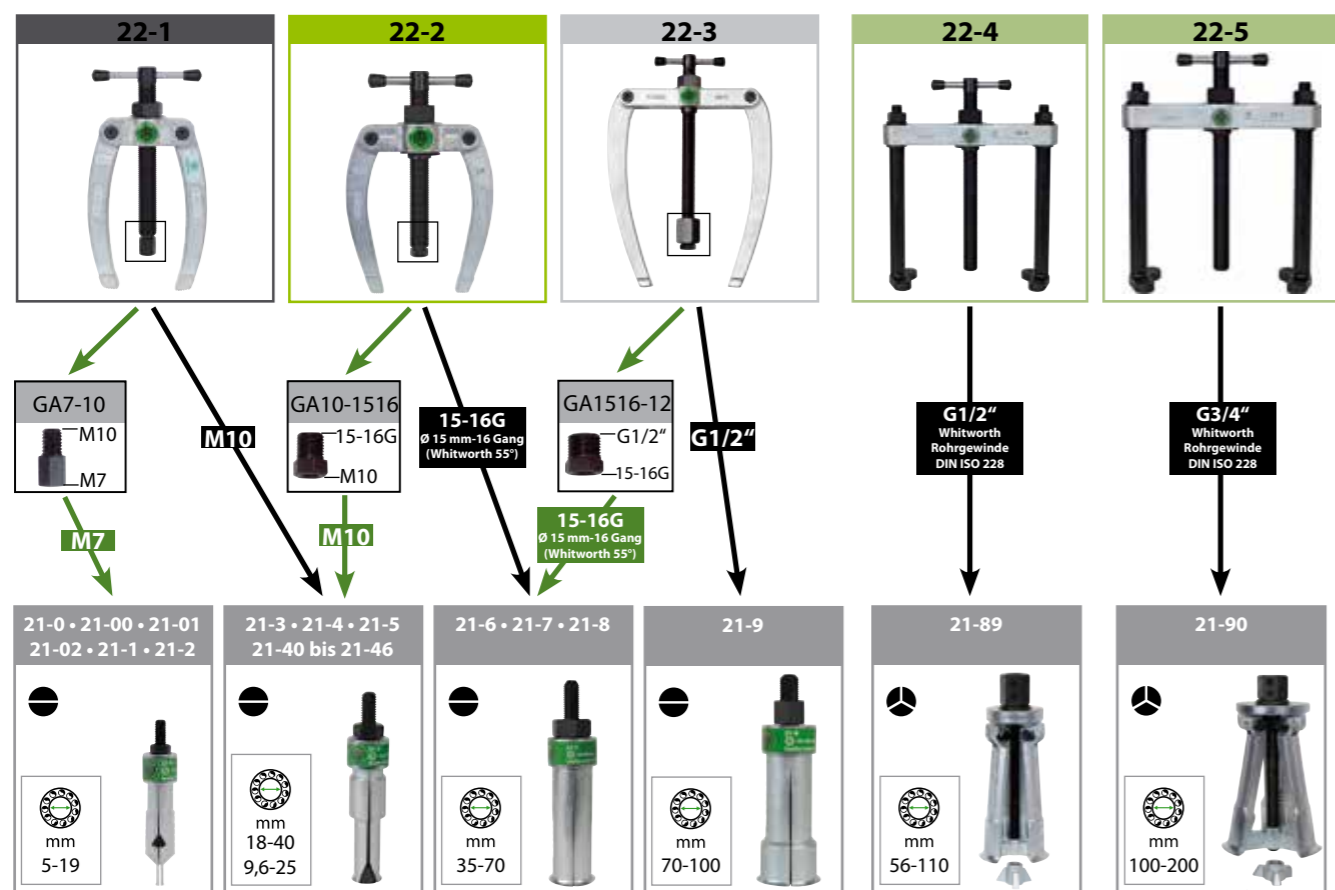

Combination of counter stay with segmented internal extractors, series 21-E

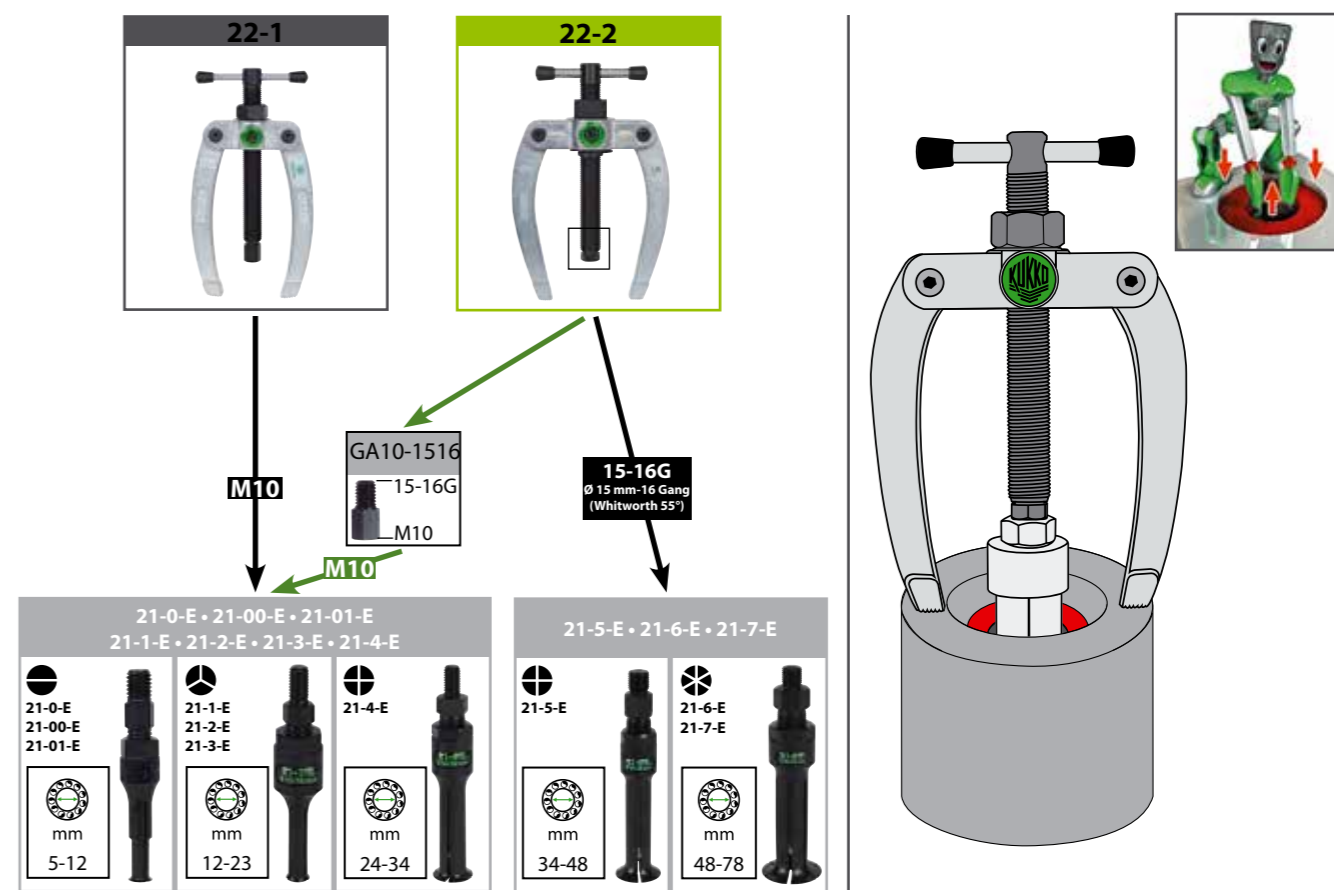

Combination of slide hammer with internal extractors, series 21

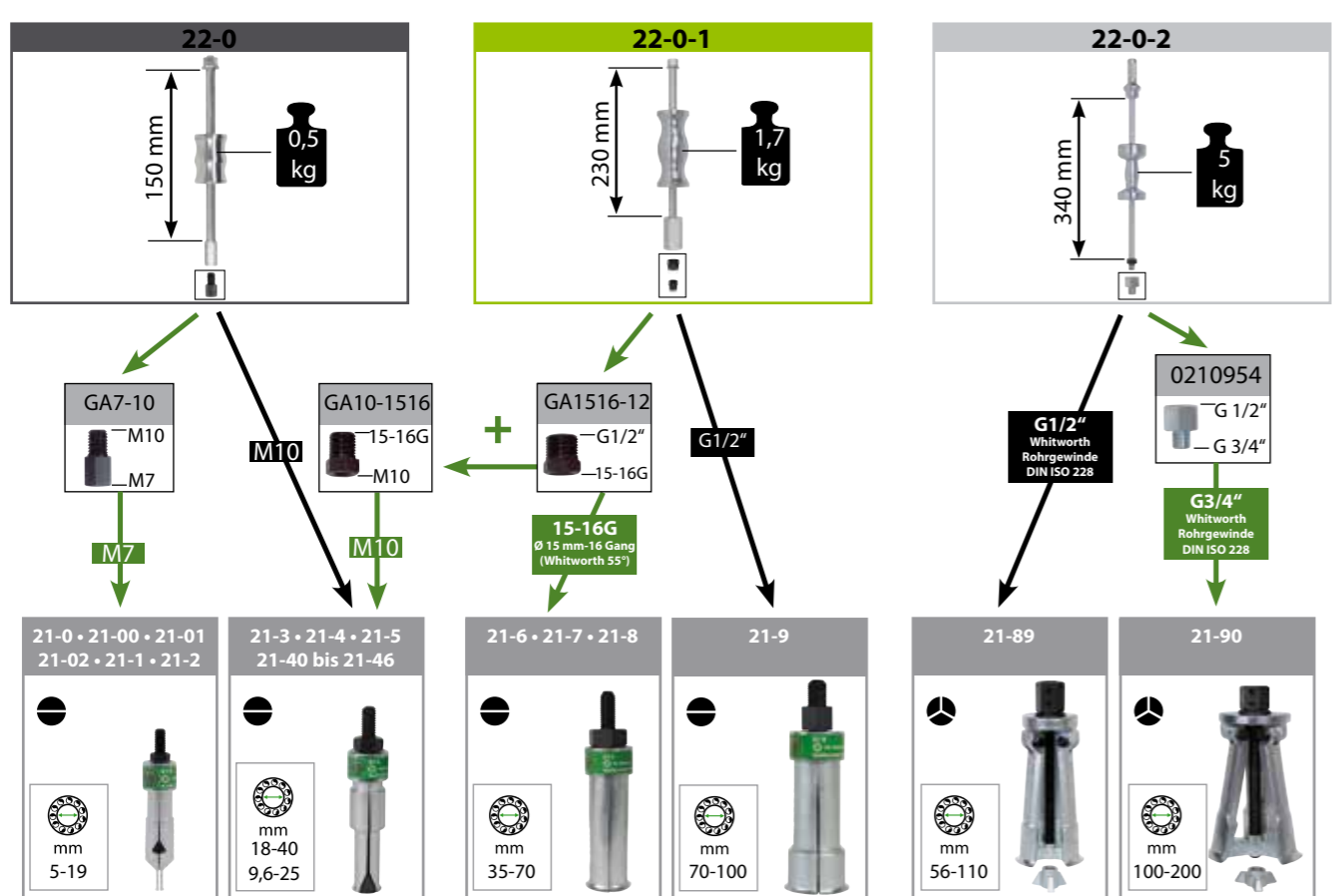

Combination of slide hammer with segmented internal extractors, series 21-E

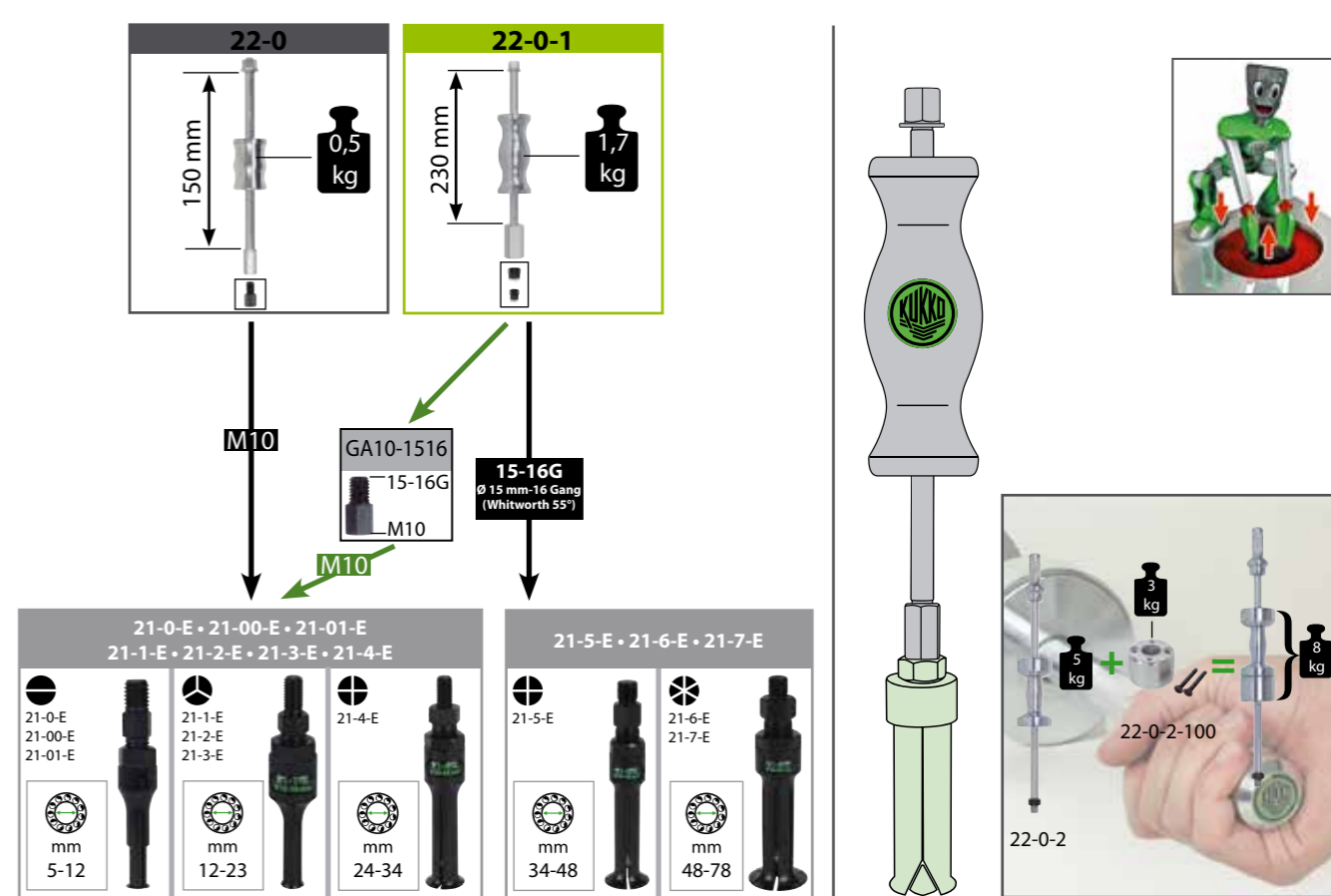

Selection of the right separating type



The part to be removed is level. It is not possible to use standard puller jaws!

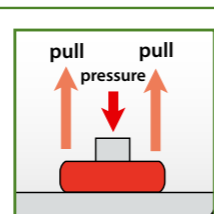

1st step: What is the diameter of the flush bearing?

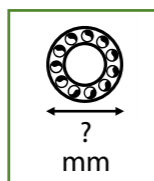

2nd step: Choice of the separator blade

2 (a) Separator series 15



6-250 mm

2 (b) Separator with quick clamping pressure spindle, series 17

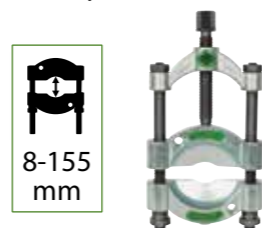

8-155 mm

TIP: One-hand operation due to quick-tension spindle

3rd step: Choice of the pulling device

3 pulling device series 18

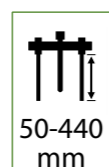

50-440 mm



4th step: Combination of the separating blade with the pulling device

4 (a) Separator



series 15 + series 18

4 (b) Separator with quick clamping pressure spindle



series 17 + series 18

Mode of operation

For pulling tight parts such as ball bearings, roller bearings, inner rings and similar. The sharp, wedge-shaped blades are pressed behind the parts to be removed and, in this process, push between the bearing and the seat. For pulling, the tension bolts on the pulling device (series 18) must be screwed into the separator.

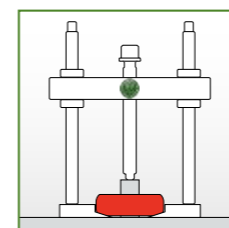

Normally, a separator blade is used in combination with a puller device.

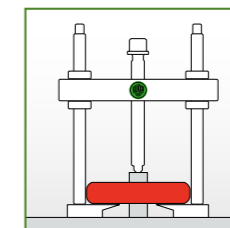

If the separating jaws are screwed into the pulling device the other way round, then pulling can be carried out flush and gently.

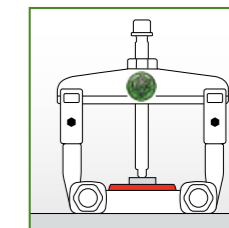

In some cases, an appropriate puller from the 20 series can be used instead of the puller bar.

Accessories: Extensions

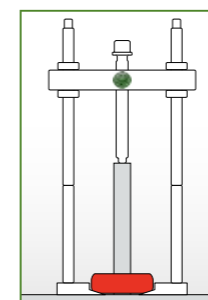

It is also possible to extend the puller bar for jobs involving longer shafts.

Accessories: long hydraulic spindles

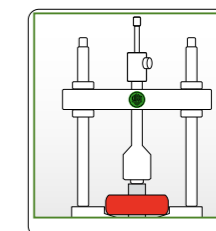

For particularly secure parts, in the larger models (from 18-2), the mechanical pressure spindle can be swapped for a hydraulic pressure spindle.

More Separators

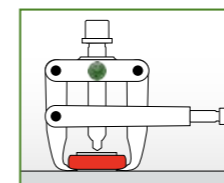

The extensive KUKKO line also supplies separators with side clamps, such as the 204 and 210 Cobra series.

Safety instructions for separating

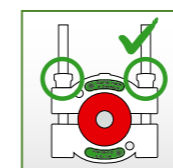

The adjusting nuts on the separator must be tightened in alternating and equal turns. Otherwise, the separator blade may tilt on the bolt or the thread may be damaged.

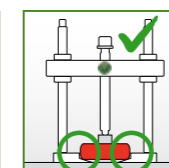

When pulling the separator blade, ensure that before the pulling device is pulled upwards the blade is firmly seated up to the stop under the part to be removed.

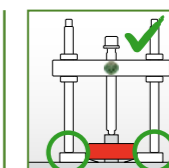
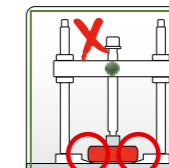

The side bolts of the pulling device must always be spindled into the separator blade until they stop.

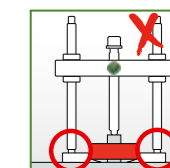

Selection of the right ball bearing extractor

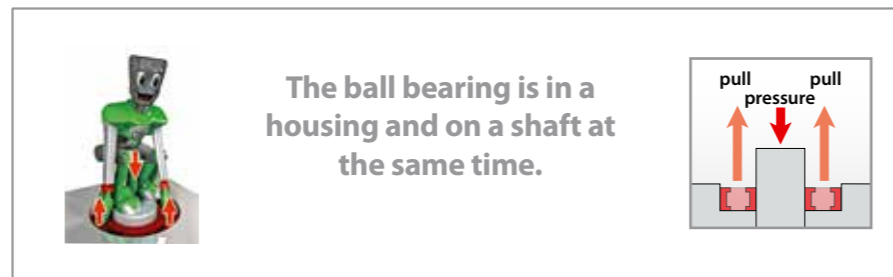

1st step: What is the ISO number of the ball bearing?

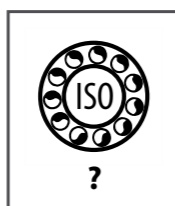

2nd step: Reusing of the ball bearing

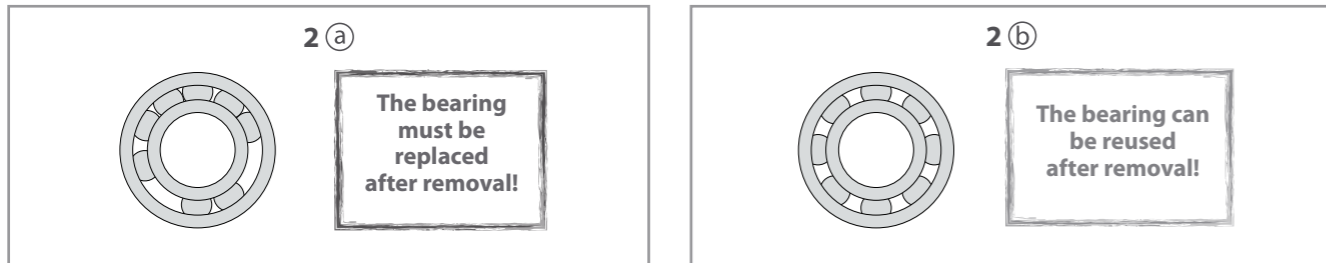

3rd step: Choice of the right ball bearing puller

3 (a) The bearing is replaced

Series 69

The cage of the damaged ball bearing needs to be drilled so that the hemispheres of the pulling parts can be screwed in.

- There arise drilling chips

Series 70

The jaws of the puller arms catch between the balls and the outer ring of the bearing.

- Clean working

3 (a) The bearing can be used again

Series 70

Non-destructive pulling using the 70 series does not damage the ball bearing. The jaw of the puller arm grips between the ball and the outer ring of the bearing.

- Clean working

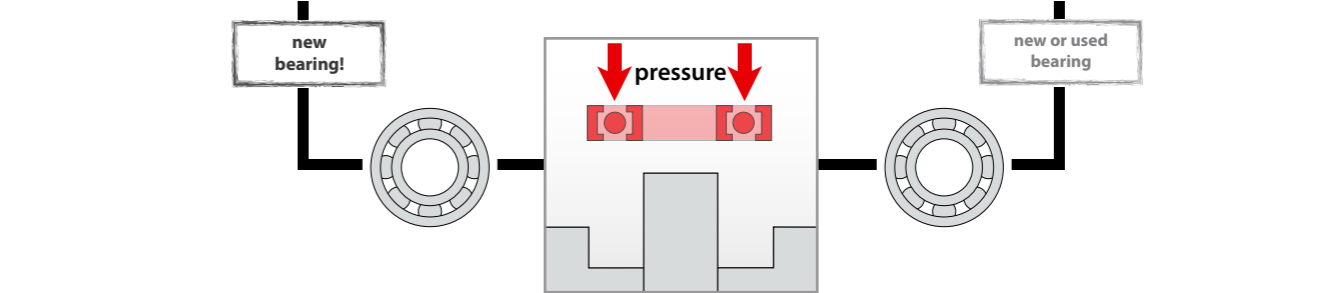
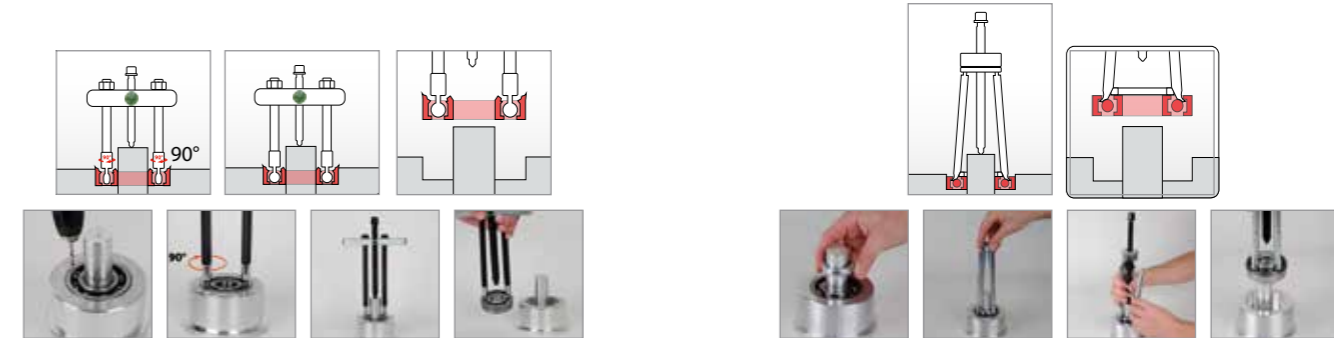
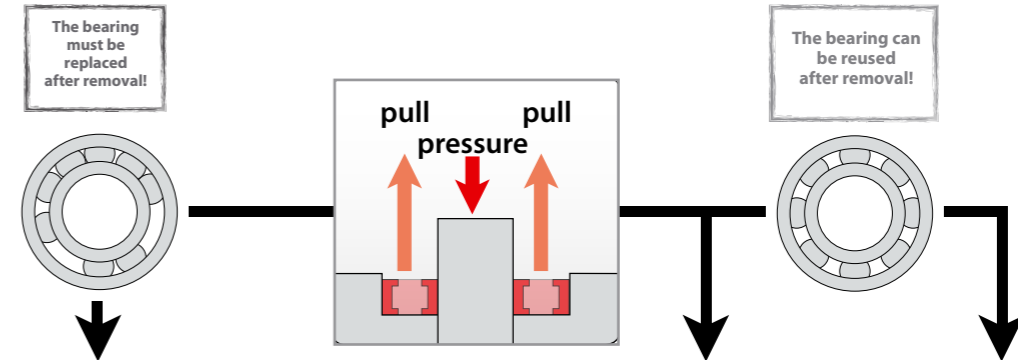

Workshop model heavy duty

kg 18,6

71

Workshop model heavy duty, short model

kg 8,6

71-K

Out of field model light duty

kg 4,6

71-L

TIP! For an especially reliable fit of the ball bearing onto the shaft, we recommend our inductive ball bearing heater, T-AW. The ball bearing is heated, mounted on the shaft, and as it cools, is firmly pressed to the shaft.



- ▶ Save keeping of the tools in special foam
- ▶ Instructions in the cover always remain visible with:
 - Statement of contents
 - Usage diagrams
 - Safety notes
- ▶ If you register online, the manufacturer's guarantee increased to 3 years.
- ▶ KUKKO special sliding grease for pressure spindl included
- ▶ Completeness - easy to check at a glance
- ▶ Connectable with the systems of other well known manufacturers



ONE SYSTEM. A LOT OF POSSIBILITIES.

With the KUKKO i-Boxx and L-BOXX-System you get all opportunities. You can equip it with insert-boxes, deep drawn parts, foam inlets and different applications for the lid. Your tools, small parts or spare parts will be kept and transported safely and well arranged. The KUKKO-i and L-BOXX-System is the perfect mobile solution and can be integrated easily into most vehicles.

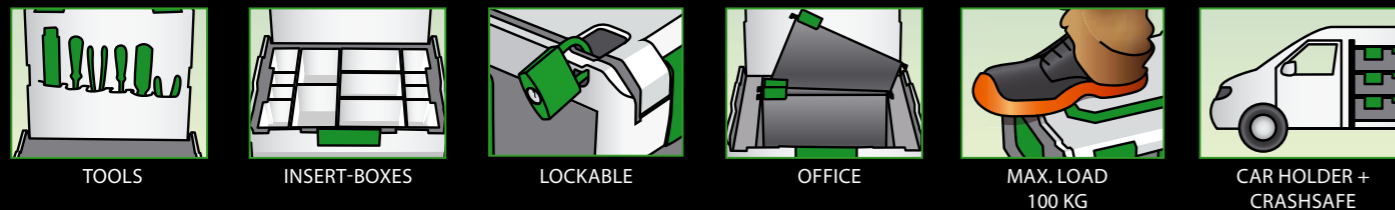

EXTERNAL pulling



INTERNAL pulling



SEPARATING



BALL BEARING removal and installation



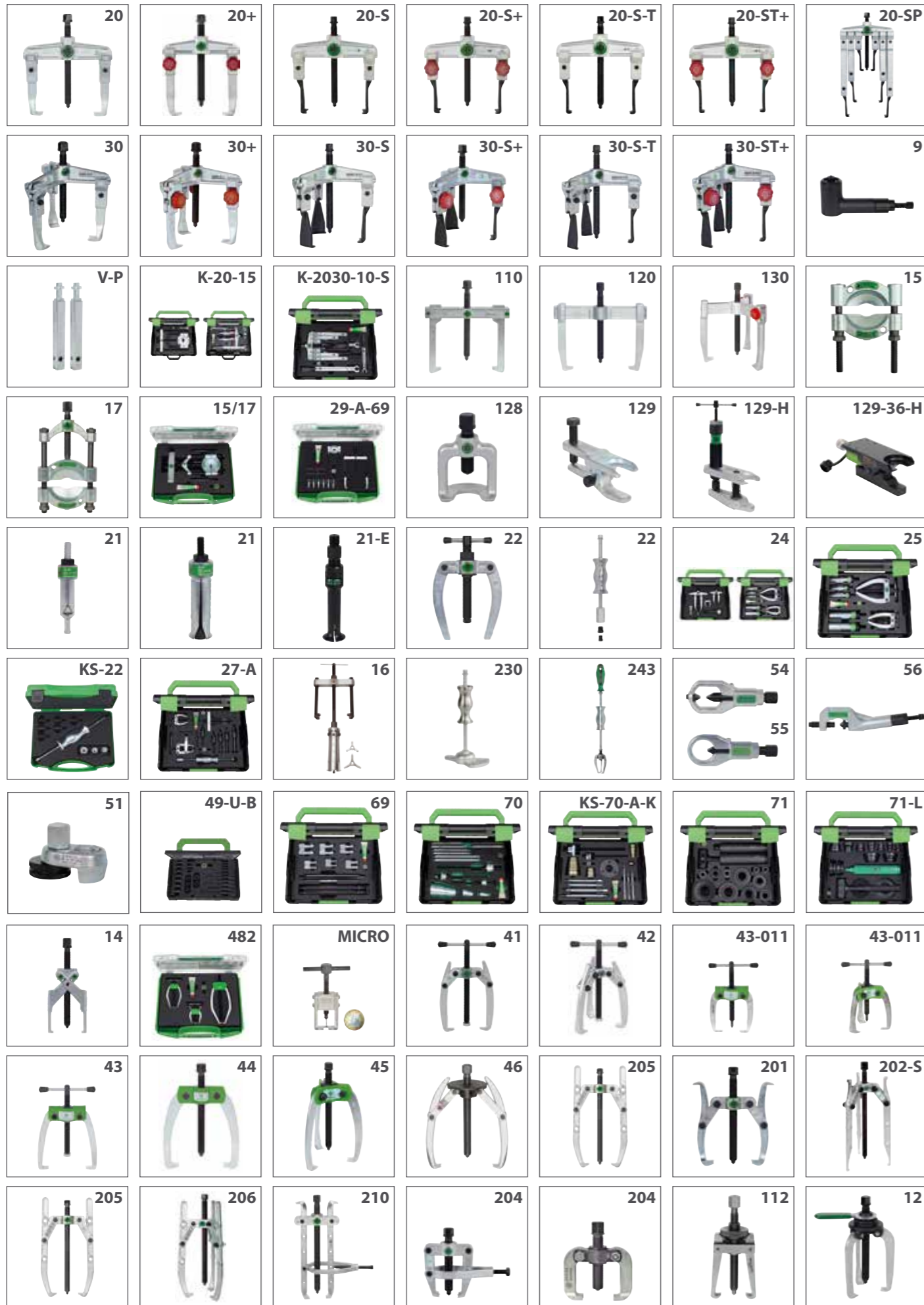

On mondo in movimento En värld i rörelse
Мы приводим в движение мир Een wereld
mailman liikkeessä Un mundo en movimient
en i bevægelse En verden i bevægelse
Eine Welt in Bewegung



KUKKO-Werkzeugfabrik
Kleinbongartz & Kaiser oHG
Heinrich-Hertz-Str. 5 · 40721 Hilden · GERMANY
Phone: +49 2103 9754-400 · Fax: +49 2103 9754-420
info@kukko.com · www.kukko.com



KUKKO on Facebook
www.facebook.com/kukkotools

